



Owner's Manual

Dear Valued Customer,

Thank you for your purchase of a Generation Hot Tubs Spa. We are sure you will have many years of enjoyment with your Generation Hot Tubs Spa. Whether relaxing from a busy day, reconnecting with loved ones or just enjoying the massaging jets, you will find your mind and body are both soothed and rejuvenated.

Enclosed in this manual is valuable information on the proper installation by your Generation Hot Tubs Authorized Dealer, along with operating instructions and helpful tips on enjoying your new Generation Hot Tubs Spa. Also, you can enter your spa's information in the Record of Ownership section on page 23 for quick reference in the future.

Also enclosed in this manual is a warranty card that should be filled out and returned to the factory. This allows us to register your purchase and enter your information into our database. Please send the completed warranty form to:

Generation Hot Tubs
Warranty Department
326 Garfield St.
McMinnville, TN 37110

(Your data will not be sold to any outside parties)

We thank you for your purchase of a Generation Hot Tubs Spa.

And now...Sit back and "Relax, you've earned it."

Sincerely,

The Generation Hot Tubs Team



Manual Overview

Page	Contents
4-8	Important Safety Instructions
9	General Guidelines Site Preparation
10	Electrical Requirements
11	Electrical Installation Instructions
12-13	Electrical Safety
14	Understanding Spa Controls and Features
15	Beginning Startup Procedures
15-16	Hot and Cold Weather Use
16-17	Troubleshooting
18	Recommendations for Maintenance
19-20	Codes, Meanings and Actions Required
21	Chemical Instructions
22	Other WARNINGS!
23	Record of Ownership
24-38	TP500 and TP500S Control Panels

IMPORTANT SAFETY INSTRUCTIONS

1. READ AND FOLLOW ALL INSTRUCTIONS

2. **DANGER** - Do not lay across the foot well. Always sit in an upright position.
3. **WARNING** - To reduce the risk of injury, do not permit children to use this product unless they are closely supervised.
4. **CAUTION** - Water temperature may rise when jets are operating on “high” speed for extended duration.
5. A bonding lug has been provided on the outside of the Equipment Package electrical control box. The lug permits the connection of No. 8 AAWG (8.42mm²) solid copper bonding conductor between the Equipment Module and all other electrical equipment and exposed metal in the vicinity, as may be needed to comply with local regulations.
6. **WARNING** - This unit must be hardwired only to supply circuit that is protected by ground fault circuit interrupter (GFCI) see diagram. Such a GFCI is required by most building codes and should be provided by the installer and must be tested before each use. Consult GFCI manufacturers’ instructions for correct testing and operation.
7. The electrical supply for this product must include a suitable rated switch or circuit breaker to open all ungrounded supply conductors to comply with the National Electrical Codes. The disconnection means must be readily accessible to the tub occupant but installed at least 5 feet (1.5M) from spa water.
8. Spas must be installed with drainage for electrical equipment compartment.
9. Be sure the water always flows freely from the hydrotherapy jets within the spa. Any blockage or restriction to this water flow by persons or objects may damage system components, create an electrical shock hazard, and or cause water damage to the surrounding area.
10. To avoid damage to the pump(s) and heater, the Equipment must never be operated unless the spa is filled with water.

WARNING: CHILDREN SHOULD NOT USE SPAS OR HOT TUBS WITHOUT ADULT SUPERVISION

AVERTISSEMENT: NE PAS LAISSER LES ENFANTS UTILISER UNE CUVE DE RELAXATION SANS SURVEILLANCE

WARNING: DO NOT USE SPAS OR HOT TUBS UNLESS ALL SUCTION GUARDS ARE INSTALLED TO PREVENT BODY AND HAIR ENTRAPMENT

AVERTISSEMENT: POUR ÉVITER QUE LES CHEVEUX OU UNE PARTIE DU CORPS PUISSENT ÊTRE ASPIRÉS, NE PAS UTILISER UNE CUVE DE RELAXATION SI LES GRILLES DE PRISE D’ASPIRATION NE SONT PAS TOUTES EN PLACE

WARNING: PEOPLE USING MEDICATIONS AND/OR HAVING AN ADVERSE MEDICAL HISTORY SHOULD CONSULT A PHYSICIAN BEFORE USING A SPA OR HOT TUB.

AVERTISSEMENT: LES PERSONNES QUI PRENNENT DES MÉDICAMENTS OU ONT DES PROBLÈMES DE SANTÉ DEVRAIENT CONSULTER UN MÉDECIN AVANT D'UTILISER UNE CUVE DE RELAXATION.

11. **WARNING** - Extreme caution must be exercised to prevent unauthorized access by children. To avoid accidents, ensure that children cannot use this spa unless they are always supervised.

12. **WARNINGS - WATER TEMPERATURE.** Never heat your spa water above 104°F (40°C). If you do, it could cause serious health hazards.

13. **DANGER-RISK OF ELECTRICAL SHOCK.** Install at least 5 feet (1.5m) from all metal surfaces. (A spa may be installed within 5 feet of metal surfaces if each metal surface is permanently connected by a minimum No. 8 AWG (8.4 mm²) solid copper conductor attached to the wire connector on the terminal box that is provided for this purpose.)

14. **DANGER-RISK OF ELECTRICAL SHOCK.** Do not permit any electrical appliance such as a light, telephone, radio, or television within 5 feet (1.5m) of a spa.

15. **WARNING** - Water temperature more than 38°C may be injurious to your health.

AVERTISSEMENT: IL PEUT ÊTRE DANGEREUX POUR LA SANTÉ DE PLONGER DANS DE L'EAU À PLUS DE 38°C

16. **WARNING** - Pregnant or possibly pregnant women should consult a physician before using a spa or hot tub.

AVERTISSEMENT: LES FEMMES ENCEINTES, QUE LEUR GROSSESSE SOIT CONFIRMÉE OU NON, DEVRAIENT CONSULTER UN MÉDECIN AVANT D'UTILISER UNE CUVE DE RELAXATION.

17. **WARNING** - Do not use a spa or hot tub immediately following strenuous exercise.

AVERTISSEMENT: NE PAS UTILISER UNE CUVE DE RELAXATION IMMÉDIATEMENT APRÈS UN EXERCICE FATIGANT.

18. **WARNING** - Prolonged immersion in a spa or hot tub may be harmful to your health.

AVERTISSEMENT: D'UTILISATION PROLONGÉE D'UNE CUVE DE RELAXATION PEUT ÊTRE DANGEREUSE POUR LA SANTÉ LA.

19. **WARNING** - To avoid injury, exercise care when entering or exiting the spa or hot tub.

AVERTISSEMENT: POUR ÉVITER DES BLESSURES, USER DE PRUDENCE EN ENTRANT DANS UNE CUVE DE RELAXATION ET E-.: SORTANT.

20. **DANGER – RISK OF INJURY.** The suction fittings in this spa are sized to match the specific water flow created by the pump. Should the need arise to replace the suction fittings or the pump, be sure that the flow rates are compatible. Never operate spa if the suction fittings are broken or missing. Never replace a suction fitting with one rated less than the flow rate marked on the original fitting.

21. The ideal temperature of your spa or hot tub should be between 95° and 104° F (35°- 40° C). This range is not only healthier but will also result in easier care of your spa.

22. Since excessive water temperatures have a high potential for causing fetal damage during the early months of pregnancy, pregnant or possibly pregnant women should limit spa temperatures to 100° F (38° C) or less.

23. Before entering a spa, the user should measure the water temperature with an accurate thermometer since the tolerance of water temperature regulating devices may vary as much as +/-5 degrees.

24. The use of alcohol, drugs, or medication before or during spa use may lead to unconsciousness with the possibility of drowning.

25. Persons suffering from obesity or with a medical history of heart disease, low or high blood pressure, circulatory system problems or diabetes should consult a physician before using a spa.

26. Persons using medication should consult a physician before using a spa since some medication may induce drowsiness while other medication may affect heart rate, blood pressure and circulation.

27. Because occasional users of the spa may not be aware of all the potential risk associated with spa usage, they should be made aware of these Important Safety Instructions.

28. **CHEMICAL SAFETY - Play it safe with chemicals.**

29. Maintain sanitizer level of 3-5 PPM of bromine or chlorine.

30. Do not mix chemicals with each other before adding them to the water. Add only one chemical at a time.

31. Never add concentrated liquid chemicals directly to the water. Always dilute chemicals in a large plastic bucket or pail before adding them.

32. When diluting chemicals, always add them to the water. Never add water to the chemicals.

33. Always dilute the chemical slowly and evenly before adding into the water. Never add any chemical, diluted or otherwise, into any skimmer device.

34. Always store chemicals according to the manufacturer's label directions and keep them out of reach of children.

35. A green colored terminal or a terminal marked G, GR, Ground, Grounding, or the symbol* is located inside the supply terminal box or Compartment. To reduce the risk of electric shock, this terminal must be connected to the grounding means provided in the electric supply service panel with a continuous copper wire equivalent in size to the circuit conductors supplying this equipment. *IEC Publication 417, Symbol 5019.

36. At least two lugs marked "BONDING LUGS" are provided on the external surface or on the inside of the supply terminal box or compartment. To reduce the risk of electric shock, connect the local common bonding grid around the hot tub or spa to these terminals with an insulated or bare copper conductor not smaller than No. 8 AWG.

37. All field-installed metal components such as rails, ladders, drains or other similar hardware within 5' of the spa or hot tub shall be bonded to the equipment grounding bus with copper conductors not smaller than No. 8 AWG.

STEREO SPA SAFETY INSTRUCTIONS

- A. **“CAUTION”** - Risk of Electric Shock. Do not leave compartment door open. Self-closing door provided.
- B. **“CAUTION”** - Risk of Electric Shock. Replace components only with identical components.
- C. **“WARNING”** - Prevent Electrocutation. Do not connect any auxiliary components (for example cable, additional speakers, headphones, additional audio / video components, etc.) to the system.
- D. Do not service this product yourself as opening or removing covers may expose you to dangerous voltage or other risk of injury. Refer all servicing to qualified service personal.

SAVE THESE INSTRUCTIONS.

Hyperthermia

WARNING: THE USE OF ALCOHOL OR DRUGS CAN GREATLY INCREASE THE RISK OF FATAL HYPERTHERMIA IN HOT TUBS AND SPAS

LA CONSOMMATION DI ALCOOL OU DE DROGUE CONSIDERABLEMENT LES RISQUES D’HYPERTHERMIE MORTELLE DANS UNE CUVE DE RELAXATION.

The causes, symptoms, and effects of hyperthermia may be described as follows.

Hyperthermia occurs when the internal temperature of the body reaches a level several degrees above the normal body temperature of 98.6° F (37° C).

The Symptoms of Hyperthermia Include:

- Dizziness
- Fainting
- Drowsiness
- Lethargy
- Increase in Internal Body Temperature

The Effects of Hyperthermia Include:

- Unawareness of Impending Danger
- Failure to Perceive Heat
- Failure to Recognize the Need to Exit Spa
- Physical Inability to exit Spa
- Fetal Damage in Pregnant Women
- Unconsciousness Resulting in a Danger of Drowning

General Guidelines for Site Preparation

Requirements for Access:

The size of the actual spa you choose will determine the amount of space needed to move the spa from the street to its final resting area. Be sure to measure all gate and door openings, also look for any vertical obstructions such as roof overhangs and power lines. Also consider trees, shrubs, deck railings, etc. You will need at least 1ft clear on either side of the spa.

Inside Installation:

(We do not recommend installing hot tubs inside. Any damage caused by leaks or any other concerns are not covered). If you are installing the spa indoors, make sure that there are no areas with dimension limitations such as ceilings, stairs, hallways, and walls based on the size of the spa you chose. Also make sure that the floor in the area the spa is placed will handle the weight. Water weighs just over 8 lbs. (3.5 kg) per gallon so consider the filled weight of your spa including the weight of users.

Pad and Surface requirements:

We require a 3 to 4" (7.5-10 cm) completely flat reinforced concrete surface. When a spa is filled and has occupants, it can weigh several tons so care must be taken when placing on any surface other than solid concrete 3 to 4" (7.5 -10 cm) thick. Therefore, when placing on a deck, balcony or indoors, you must make sure that the surface can offset at least 100 lbs. (45 kg) per square foot. Your dealer is not usually qualified to make judgments on weight bearing abilities of structures, so always consult a qualified professional in that area of expertise.

Spa Placement

When deciding where to place the spa in the area you have available you should think of:

1. Where the electricity will come into the spa, where you will enter the area, and where you will enter the spa.
2. Will there be access to all sides of the spa for future service? Note: If you choose to place the spa in a place where any side is covered and access is limited, if you need any kind of service whether warranty or regular pay that requires additional time to gain access, you will most likely be assessed additional fees for service.
3. Also consider if you will be using a cover lift. For a side mount style, you will need about 24" (61 cm) of extra space on the side your cover will rest on. If you have limited space there are other types of lifts available to lift the cover without needing any space outside of the spa. If you are placing your spa under a roof, the space between the top of your spa and the bottom of the roof needs to be at least half of your cover plus 6" (15 cm) to lift off the cover. If you choose to place your spa into an area that has a structure built around it, any damage to the structure that is caused by that spa is not covered by the warranty. Example: leaks in a room that damage carpet or wood floor, etc.

You should have a disconnect at the spa for all applications which should be located within sight from equipment.

Electrical Requirements

It is the responsibility of the Spa owner to make sure that all electrical connections are made by a Qualified Electrician in accordance to the National Electrical Code and/or any local or State Electrical Codes that may be enforceable at the time of installation. All connections must be made in accordance with the wiring Diagram/ Instructions inside the Spa Control Pack.

Please have your electrician read the following instructions carefully before attempting installation of spa wiring.

*Always be sure that power is not applied to circuits while performing any electrical work.

**You can install your incoming wire anywhere in the cabinet. We recommend placing it close to the source of the incoming electricity and run it through the cabinet to the spa pack. Place a seal around the conduit placed through the hole in the side panel.

All 120 Volt capable spas require a Dedicated 15 AMP GFCI service connection. An optional 15 Amp GFCI 12ft cable is available from Generation Hot Tubs. Never use an extension cord to run your spa. Meeting this standard may require you to have your standard receptacle and/or circuit breaker upgraded by a Licensed Electrician. National Electrical Code 680-42

For 230 Volt spas, 1 and 2 pump spas require a Dedicated 50 AMP service connections with a 6/3 AWG (Four Wire) All Copper Conductors. National Electrical Code 422-20.

**Note: EU spas require 32 Amp R.C.D. with a 6 or 8/2 AWG (Three Wire) All Copper Conductors. Code also requires a disconnect that is readily accessible to spa users, but at least 5 feet from spa.

We recommend using 230Volt Connections in all spas that are 230Volt capable to conserve electricity by getting the most use from the heater element. All our spa equipment is designed to operate on 60Hz alternating current. The exception is EU models that are designed to operate on 50Hz.

Electrical Installation Instructions

A copper bonding lug connector has been provided on the Spa Control Pack to allow for connection to local ground points. A 6 AWG copper ground wire is required and must be connected securely to a grounded metal structure item such as a cold-water pipe or the main ground lug inside of the connecting electrical panel.

1. A green colored terminal or a terminal marked G, GR, Ground, Grounding, or the symbol * is located inside the supply terminal box or Compartment. To reduce the risk of electric shock, this terminal must be connected to the grounding means provided in the electric supply service panel with a continuous copper wire equivalent in size to the circuit conductors supplying this equipment. **IEC Publication 417, Symbol 5019.*
2. A bonding lug has been provided on the outside of the Equipment Package electrical control box. The lug permits the connection of No. 8 AWG (8.42mm²) solid copper bonding conductor between the Equipment Module and all other electrical equipment and exposed metal in the vicinity, as may be needed to comply with local regulations. 02895224
3. All field-installed metal components such as rails, ladders, drains or other similar hardware within 5 feet of the spa or hot tub shall be bonded to the equipment grounding bus with copper conductors of No. 8 AWG.
4. This unit must be hardwired only to supply circuit that is protected by ground fault circuit interrupter (GFCI). A GFCI is required by all building codes and should be provided by the installer and must be tested before use. Consult GFCI manufacturers' instructions for correct testing and operation.
5. The electrical supply for this product must include a suitable rated switch or circuit breaker to open all ungrounded supply conductors to comply with the National Electrical Codes. The disconnection means must be readily accessible to the tub occupant but installed at least 5 feet (1.5M) from spa water.
6. Spas must be installed with drainage for electrical equipment compartment.
7. Do not permit any electrical appliance such as a light, telephone, radio, or television within 5 feet (1.5m) of a spa.

***Note:** Connections made improperly, or the use of wire gauge sizes for power connection which are too small, may continually blow fuses in the spa control pack, may damage the internal electrical controls and components, and/or may be unsafe and in any case will VOID the spa Warranty.

Electrical Safety

GFCI Breaker Concerns

If the GFCI breaker will not stay engaged after you wire your spa and apply power, the GFCI breaker is not wired correctly. Check the GFCI breaker wiring chart following this section and verify that all your connections are correct. Generally, if the breaker will not stay engaged, it is a wiring problem with the neutral wire. ****Note:** The neutral and the ground wires cannot touch anywhere in between the GFCI breaker and the spa. (See wiring schematic included) The white neutral wire from the spa control system must go to the Load Neutral (bottom of breaker).

50 AMP Service for 1 – 2 Pump Spas

60 AMP Service for 3 – 4 Pump Spas

Diagram 1: USA Only

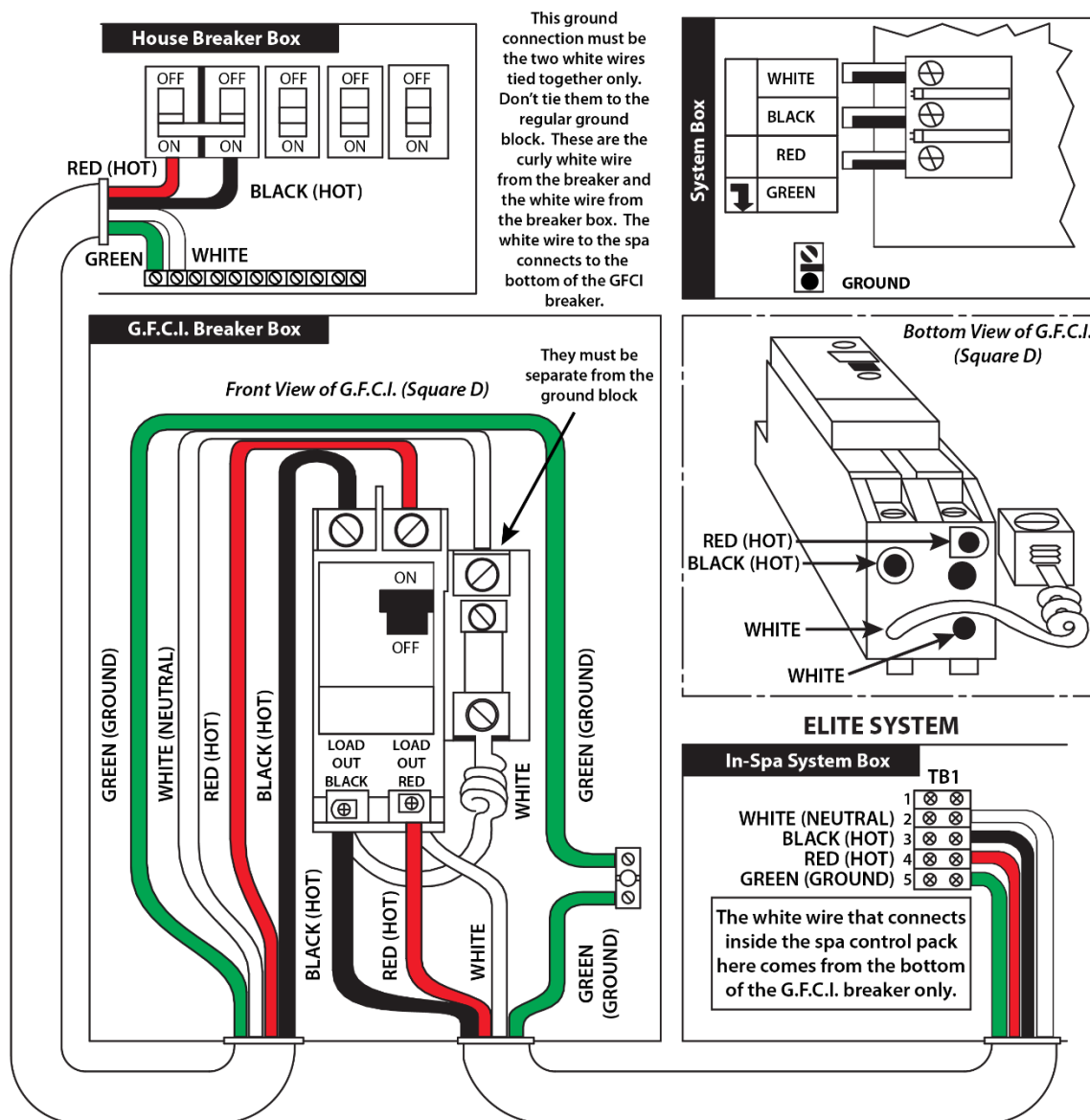

You should have a disconnect at the spa for all applications and should be located within sight from equipment.

EURO Wiring Specs (50 Hz)
1 x 32 AMP Service for 1-3 Pump Spas
2x 32 AMP Service for 4 Pump Spas

32 AMP GFCI WITH A-RATED TRIPPING
CURRENT NOT EXCEEDING 30 MA.

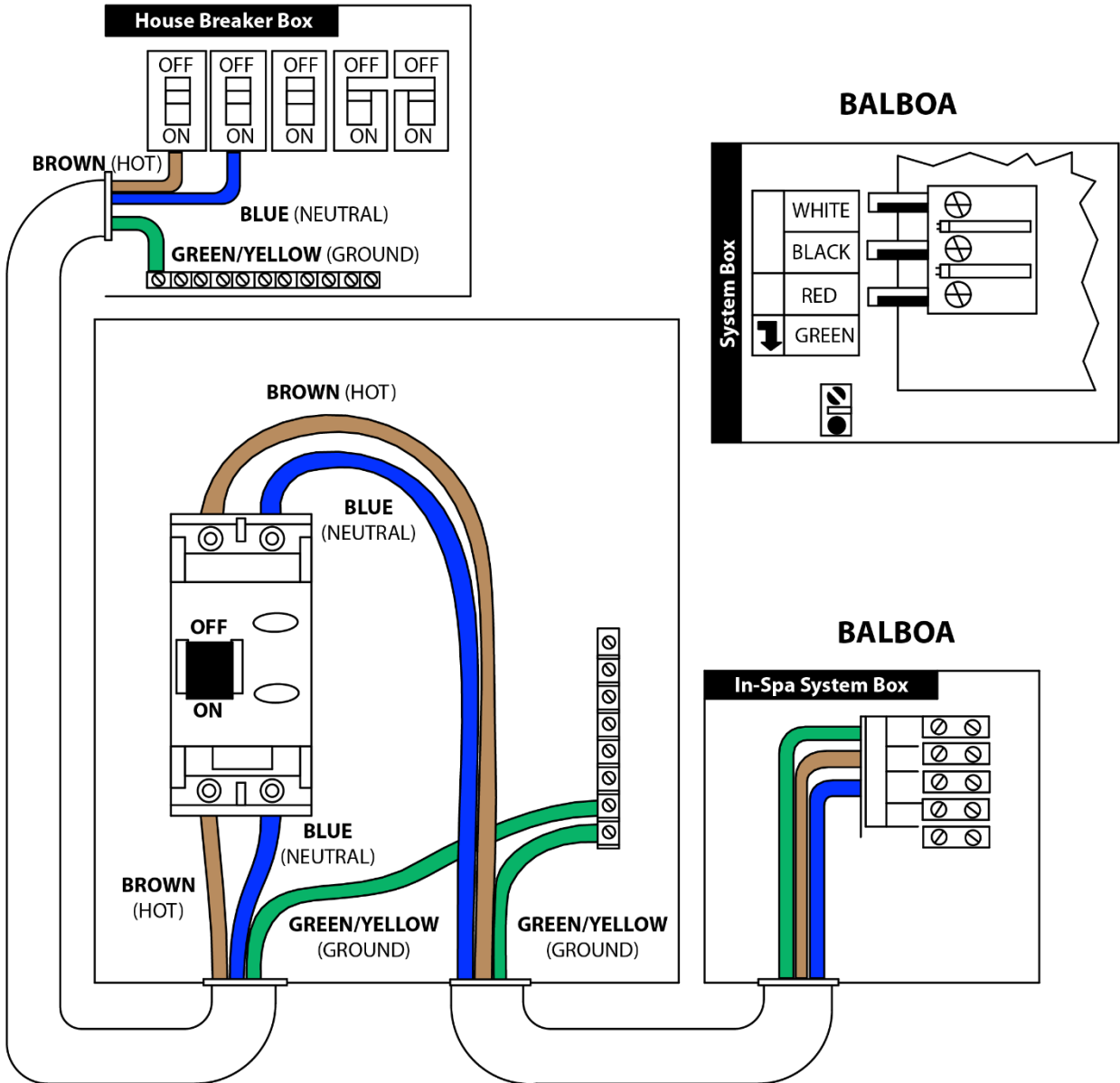

50 HZ SYSTEMS ONLY!

Servicing your spa:

Generation Hot Tubs does not recommend that you service this spa, but if you choose to open the spa electrical panel and service the spa yourself, always assume that there is power (230 Volts) to the system, unless you have verified with a test meter that there is no power to the panel. There are generally no user serviceable parts inside this panel unless you have proper training. If you are not properly trained, call your selling dealer for service. If they will not help you, then call Generation Hot Tubs Technical Service.

Understanding Spa Controls and Features

Main Jets: These jets come in various sizes and jet types. The single hole directional style can be adjusted to point in a particular direction and the whirly two-hole style will push water out in a circular pattern. These jets can be power adjusted from full power to off by turning the outside body of the jet.

LED Light System: (If equipped) The system offers several options including a series of steady light colors and variations of constant change in light colors. The light system has LED bulbs in each light assembly with a master light in the position of the main spa light that will also change colors with the rest of the system.

Outside Spa Drain: This drain is a small black port mounted on the bottom of the spa side panel. See the Recommendations for Periodic Maintenance below for instructions on how to operate the drain.

Beginning Startup Procedures

Once your spa is properly wired and ready to start, fill the spa up with water. Generally, you will fill the spa up to the bottom of the highest set of neck jets in the spa or about 6 inches above top of the floating filter housing ring. Remember this level will rise as people get into the spa, so you just want to get the water to a level that will keep it from splashing out when people are in the spa. Next, turn the power on and watch the topside control panel for either a PR or Priming Mode feature. Press the pump button for the main 2-speed pump to test the pump for water movement. If you have water movement, press the next pump button if equipped and verify movement. Repeat the same procedure until all pumps are moving water. Then watch for the heat indicator to come on the topside.

Note: *All 110V spas or any spa set in the 15 Amp mode will only heat with the two-speed pump only on low speed.*

Once the heat light is verified to be on, your spa is heating. Two pump USA spas will heat about 6-9 degrees per hour. One pump USA 230V spas will heat about 4-7 degrees per hour and 120V spas will heat about 2-3 degrees per hour. One & Two pump EU spas will heat about 4-6 degrees per hour. All these times are approximate.

If your spa has a PR or Priming Mode code on the topside, it will take 4 to 6 minutes for it to go into the regular heating mode.

Cold Weather Startup:

If your spa arrives and the environment where the spa is to be placed is 40°F or below, your Professional Installer will need to put a small ceramic heater or light bulb inside the spa cabinet to thaw out the water that may be left inside the pumps **BEFORE STARTING YOUR SPA.** If your Professional Installer starts the spa and all pump fuses blow, the pumps may have frozen water in them. Generation Hot Tubs makes every effort to remove as much water from water testing as possible before shipping, but it is impossible to remove all water from a spa plumbing system, therefore this step is crucial before starting your spa.

Hot and Cold Weather Use

Hot Weather Use:

If you choose to shut your spa down for the warmer seasons of the year you should drain as much water as possible, clean the spa shell and keep the cover in place. We recommend that you keep the spa running through this season and just turn the temperature down to a more comfortable range or change the system to sleep mode, and avoid automatic filtration between 10am and 5pm. Avoid F6, F8, FC filter cycle setting. A spa will last longer if it is allowed to run all the time.

Cold Weather Use:

Because it is impossible to remove all water from your spa, we recommend that you never shut your spa down and drain the water during the cold seasons if you live in an area where freezing would be a possibility. Freeze damage is not a covered repair. If your spa stops heating during the cold seasons, it is your responsibility to protect the spa from damage until repairs can be made. To protect your spa, you can put a heat light bulb or a small ceramic heater inside the spa cabinet and place the door back over the opening. Contact your selling dealer for recommendations for winterizing and service.

Trouble Shooting

If you need service, you should call your selling dealer first. If you are installing your spa and your electrician is still onsite, they can check the information below for help.

If Your Spa Will Not Run Upon Initial Startup:

If after you wire your spa and apply power, the spa will not run or the top side control will not light, you should first have the electrician check voltage at the spa control system. It is easy to blow fuses when first wiring a new spa if you accidentally put the wires in the wrong place, or touch anything powered in the spa control pack to ground. There is a main safety fuse in the pack that is designed to protect the whole board from a miss wire. This fuse is usually a 3/10 amp fuse. (That means less than one amp) Fuses and miss wired boards are not covered by Warranty.

If a pump will not run:

You could have blown a fuse.

***Note:**

These fuses can be aquired at most Lowe's or Home Depot and are SC or SLC 30.

****Generation Hot Tubs, or its authorized service centers will not be held responsible for damage to spa and/or components caused by improperly wired spas or any personal injury related to an owners attempt to repair a spa. Replacement costs will be the responsibility of the spa owner.**

Troubleshooting Continued

If the spa is running but not heating:

If your spa has worked and heated before with no problem and it suddenly is dropping temperature, check first to be sure you have not accidentally put the controls in the economy mode or sleep mode. On most controls you can touch the warm button then the light or mode button, to select your 3 different modes if equipped.

If your spa is running continuously:

Check your preset filter cycle setting as you may be on a longer filtration setting than needed.

Timing your filtration cycles:

Filter cycles are set using a start time and a duration. Start time is indicated by an "A" or "P" in the bottom right corner of the display. Duration has no "A" or "P" indication. Each setting can be adjusted in 15-minute increments. The panel calculates the end time and displays it automatically.

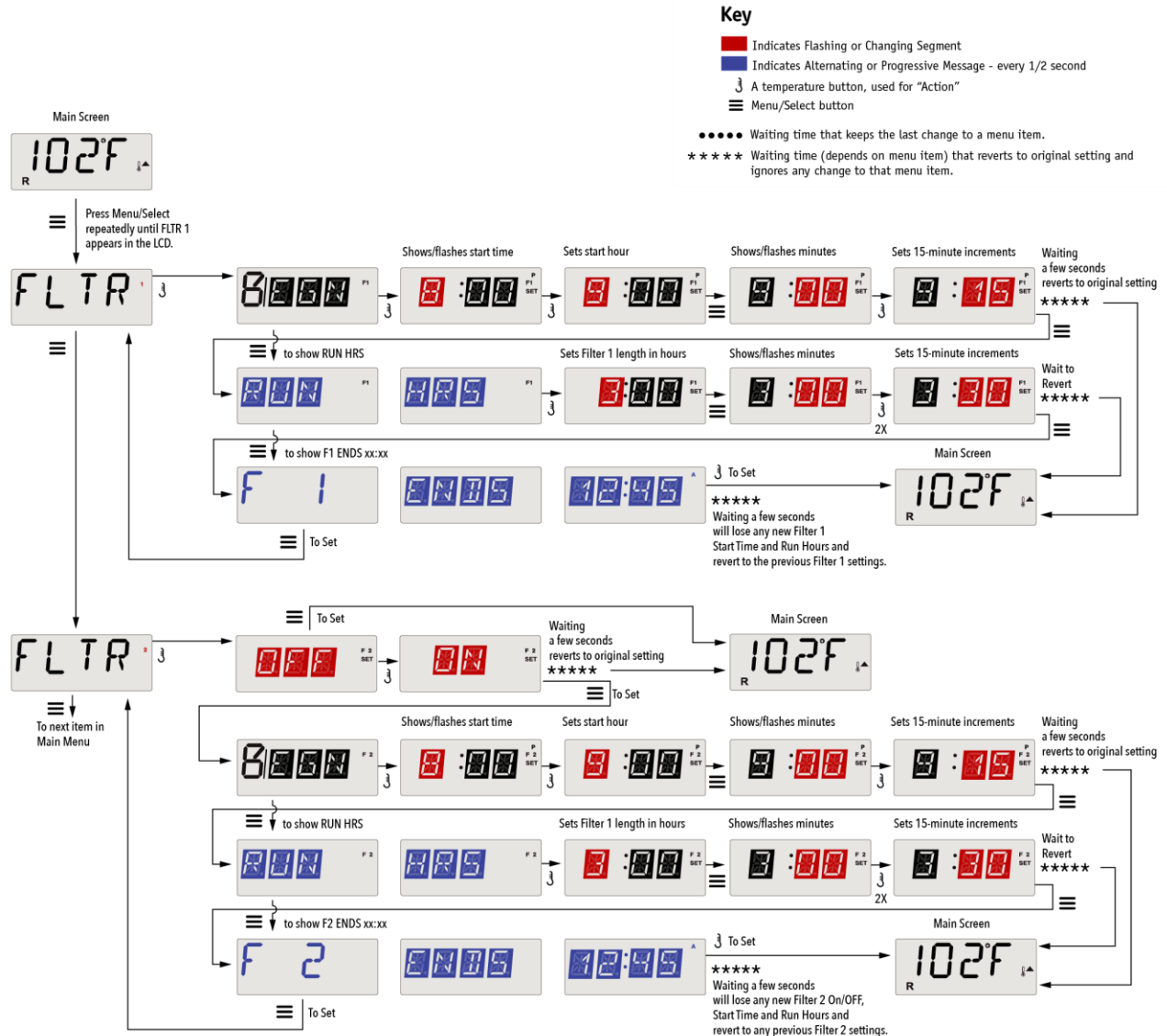

Recommendations for Maintenance

Chemical Maintenance:

It is very important that you maintain the correct level of chemicals in your spa. Otherwise, you run the risk of damaging the jets and the heating elements, as well as encouraging cloudy water and skin and eye irritations. Also remember that chemical damage is not covered under warranty.

Please refer to Chemical Safety Instructions at the back of the manual for further instructions.

Cover: Clean the cover with soap and water once per month to remove things like tree sap and dirt.

Side Panels: Wash the side panels periodically with water.

Spa Shell: When you change the water, wipe the shell down with Fast Orange or some other biodegradable cleaner and rinse the shell out and drain the water out or vacuum it out of the foot well.

Water: Replace the water 2 to 6 months based on your amount of use, personal preference, or dealer recommendations.

To drain your spa: Grab the handle on the cap with pliers and pull it straight out, then turn it about 1/4 turn to the left and then pull it out about 3". This will lock the tube into place so you can remove the cap and not lose any water. Then attach a water hose to the tube and push the tube in about half way and drain the water as needed. After finishing, simply pull the tube back out 1 inch, remove the hose, install the cap, and push the tube back in until it stops. Then twist the tube to the right and push it the rest of the way back in to hide away.

Filter: Clean the filter once a month by backwashing with garden hose or placing it in the dishwasher but do not allow it to go through the drying cycle of dishwasher. Replace the filter once a year.

To remove your filter: Never try to remove your spa filter lid, basket, or cartridge while spa pump is running. Turn spa breaker off. If you have a screw filter remove the floating weir tube and counter clock wise unscrew the filter and remove. If you have a drop in filter turn the telescopic lid counter clock wise 1/4 turn to remove, lift out the filter basket to remove filter. Reverse the process for installation. If your basket and lid will not lock, your filter cartridge is either not sitting in the housing properly or the basket is not sitting on the filter cartridge properly.

Codes, Meanings and Actions Required

<u>Code*</u>	<u>Meaning</u>	<u>Action Required</u>
None	No message on display. Power has been cut off to the spa.	The control panel will be disabled until power returns. Spa settings will be preserved until next power up.
- -	Temperature unknown.	After the pump has been running for 2 minutes, the temperature will be displayed.
HH	“Overheat” – The spa has shut down. One of the sensors has detected 118°F at the heater.	DO NOT ENTER THE WATER. Remove the spa cover and allow water to cool. Once the heater has cooled, reset by pushing any button. If spa does not reset, shut off the power to the spa and call your dealer or service organization.
OH	“Overheat” – The spa has shut down. One of the sensors has detected that the spa water is 110°F at the heater.	DO NOT ENTER THE WATER. Remove the spa cover and allow water to cool. At 107°F, the spa should automatically reset. If spa does not reset, shut off the power to the spa and call your dealer or service organization.
IC	“Ice” – Potential freeze condition detected.	No action required. The pump(s) will automatically activate regardless of spa status.
SA	Spa is shut down. The sensor that is plugged into the Sensor “A” jack is not working.	If the problem persists, contact your dealer or service organization. (May appear temporarily in an overheat situation and disappear when the heater cools.)

SB	Spa is shut down. The sensor that is plugged into the Sensor “B” jack is not working.	If the problem persists, contact your dealer or service organization. (May appear temporarily in an overheat situation and disappear when the heater cools.)
SN5	Sensors are out of balance. If alternating with spa temperature, it may just be a temporary condition. If flashing by itself, spa is shut down.	If the problem persists, contact your dealer or service organization.
HL	A significant difference between temperature sensors has been detected. This could indicate a flow problem.	Check water level in spa. Refill if necessary. If the water level is okay, make sure the pumps have been primed. If problem persists, contact your dealer or service organization.
LF	Persistent low flow problems. (Displays on the fifth occurrence of “HL” message within 24 hours.) Heater is shut down, but other spa functions continue to run normally.	Follow action required for “HL” message. Heating capability of the spa will not reset automatically; you may press any button to reset.
DR	Possible inadequate water, poor flow, or air bubbles in detected in the heater. Spa is shut down for 15 minutes.	Check water level in spa. Refill if necessary. If water level is okay, make sure the pumps have been primed. Press any button to reset, or this message will automatically reset within 15 minutes. If problem persists, contact your dealer or service organization.
DY	Inadequate water detected in heater. (Displays on third occurrence of “DR” message.) Spa is shut down.	Follow action requires for “DR” message. Spa will not automatically reset. Press any button to reset.

***Note:** Not all codes pertain to all spas.

Chemical Instructions:

Important numbers of reference:

-Maintain Total Alkalinity level of 80 – 120 PPM.

-Maintain sanitizer level of 3.0 – 5.0 PPM for bromine or 1.5 – 3.0 PPM for chlorine.

Maintain Ph level of 7.2 to 7.8.

Maintain calcium hardness level of 100- 250 PPM.

Recommended items to purchase:

-Ph test strips

-Spa Up and Spa Down, or Ph Balance

-Spa Defender

-Calcium Booster

It is important to first maintain the total alkalinity levels at 80 – 120 PPM. Total alkalinity is the ability to control Ph levels. To do this, you will need *Spa Up* and *Spa Down*. Once you are sure your total alkalinity levels are within the correct range, you then need to maintain correct Ph levels of 7.2 to 7.8. For this you will need *Ph test strips* and either *Spa Up* and *Spa Down* or *Ph Balance*. You should also maintain the correct sanitizer level to disinfect the spa and keep the water smelling fresh. This can be done with a *Nature 2 sanitizer stick* or *Spa Frog*. The correct sanitizer level is 3.0 – 5.0 PPM for bromine or 1.5 – 3.0 PPM for a chlorine system. You will also need to maintain your calcium hardness levels at 100 – 250 PPM. You can use your test strips to measure it. Calcium hardness is sometimes called total hardness and is simply a measure of the minerals in your water including calcium and magnesium. If you do not have enough hardness, your spa will draw from other metals such as copper, aluminum and iron in the heating elements, pump seals and internal components. If your spa has too much hardness, this will encourage scale formation and cloudy water. We recommend you fill your spa with water from a softener, especially if you think your tap water is too hard. There is no known way to decrease calcium hardness, but *Spa Defender* is a good way to prevent against scale formation. If the calcium level is too low, you can use *Calcium Booster*.

Additional notes:

1. Do not mix chemicals with each other before adding them to the water. Add only one chemical at a time.
2. Never add concentrated liquid chemicals directly to the water. Always dilute chemicals in a large plastic bucket or pail before adding them.
3. When diluting chemicals, always add them to the water. Never add water to the chemicals.
4. Always dilute the chemical slowly and evenly before adding into the water. Never add any chemical, diluted or otherwise, into any skimmer device.
5. Always store chemicals according to the manufacturer's label directions and keep them out of reach of children.
6. To maximize efficiency of chemicals, change the water in your spa every 3 months.

WARNINGS!

DANGER RISK OF PERSONAL INJURY OR DEATH

Never Operate the spa if a suction fitting, suction cover, filter, filter lid or weir assembly are broken, damaged or missing.



DANGER RISK OF SEVERE INJURY OR DROWNING!

Entrapment may occur if hair is entangled, knotted, or snagged in a suction drain or filter lid, or weir assembly. This has been reported in persons who when submerging themselves underwater, allowing hair to come close and/or within the reach of the suction fittings, suction covers, filter, filter lid or filter weir.

Children are at risk for hair entrapment if swimming under water. Never allow children to play or get near the suction fittings, suction covers, filter, filter lid or filter weir.

DANGER DO NOT BLOCK!

DO NOT BLOCK THE SUCTION COVERS FOR ANY REASON

Generation Hot Tubs Record of Ownership

Generation Hot Tubs Model:	
Serial Number:	
Date Purchased:	
Dealer Name:	
Dealer Number:	
Dealer Address:	
Dealer City/State:	
Service Technician:	
Other Info:	



TP500 and TP500S Control Panels

User Guide for Simplified Menu

System Model: All BP series systems that support Simplified Menus

Panel Model: TP500 and TP500S Series

Panel Software Version: All versions



TP500S



TP500

Display Icons



- | | | |
|-----------------------------|-------------------|--------------------------------------|
| A - Heat | F - Light | K - Auxiliary (Jets 3 or MICROSilk®) |
| B - Ready Mode | G - Cleanup Cycle | L - Temperature Range (High / Low) |
| C - Rest Mode | H - Jets 1 | M - Set (Programming) |
| D - bba™2 On | I - Jets 2 | N - Filter Cycle (1 or 2 or Both) |
| E - WiFi (Cloud Connection) | J - Blower | |

MicroSilk® is a registered trademark of Jason International.

Manufactured under one or more of these patents. U.S. Patents: 5332944, 5361215, 5550753, 5559720, 5,883,459, 6253227, 6282370, 6590188, 6976052, 6965815, 7030343, 7,417,834 b2, Canadian Patent: 2342614, Australian patent: 2373248 other patents both foreign and domestic applied for and pending. All material copyright of Balboa Water Group.

Main Menu

Navigation

Navigating the entire menu structure is done with 2 or 3 buttons on the control panel.



Some panels have separate WARM (Up) and COOL (Down) buttons, while others have a single Temperature button. In the navigation diagrams Temperature buttons are indicated by a single button icon. Panels that have two Temperature buttons (Warm and Cool) can use both of them to simplify navigation and programming where a single Temperature icon is shown.

The MENU/SELECT Button is used to choose the various menus and navigate each section.

Typical use of the Temperature button(s) allows changing the Set Temperature while the numbers are flashing in the LCD. The menus can be exited with certain button presses. Simply waiting for a few seconds will return the panel operation to normal.

Power-up Screens

Each time the System powers up, a series of numbers is displayed. After the startup sequence of numbers, the system will enter Priming Mode (See Page 3).

Key

- Indicates Flashing or Changing Segment
- Indicates Alternating or Progressive Message - every 1/2 second
- ↕ A temperature button, used for "Action"
- ≡ Menu/Select button
- Waiting time that keeps the last change to a menu item.
- ***** Waiting time (depends on menu item) that reverts to original setting and ignores any change to that menu item.

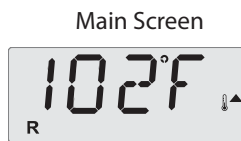
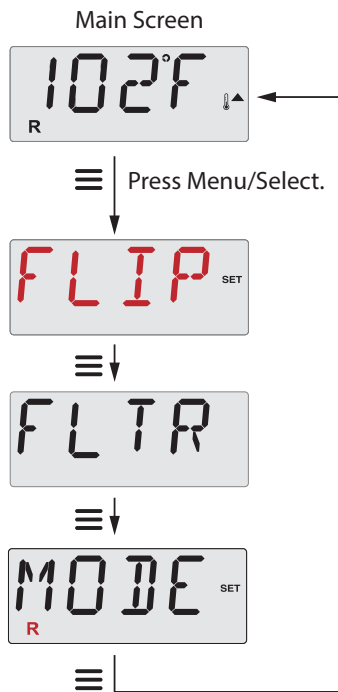

Waiting a few seconds in the Main Menu will allow the display to revert to the Main Screen. Most changes are not saved unless Menu/Select ≡ is pressed. Refer to key above.

Fill it up!

Preparation and Filling

Fill the spa to its correct operating level. Be sure to open all valves and jets in the plumbing system before filling to allow as much air as possible to escape from the plumbing and the control system during the filling process.

After turning the power on at the main power panel, the top-side panel display will go through specific sequences. These sequences are normal and display a variety of information regarding the configuration of the hot tub control.

Priming Mode

This mode will last for 4-5 minutes or you can manually exit the priming mode after the pump(s) have primed.



Regardless of whether the priming mode ends automatically or you manually exit the priming mode, the system will automatically start normal heating and filtering at the end of the priming mode. During the priming mode, the heater is disabled to allow the priming process to be completed without the possibility of energizing the heater under low-flow or no-flow conditions. Nothing comes on automatically, but the pump(s) can be energized by pushing the “Jets” or “Aux” buttons.

If the spa has a Circ Pump, it can be activated by pressing the “Light” button during Priming Mode.

Priming the Pumps

As soon as the above display appears on the panel, push the “Jets” button once to start Pump 1 in low-speed and then again to switch to high-speed. Also, push the “Jets 2” or “Aux” button, if you have a 2nd pump, to turn it on. The pumps will now be running in high-speed to facilitate priming. If the pumps have not primed after 2 minutes, and water is not flowing from the jets in the spa, do not allow the pumps to continue to run. Turn off the pumps and repeat the process. Note: Turning the power off and back on again will initiate a new pump priming session. Sometimes momentarily turning the pump off and on will help it to prime. Do not do this more than 5 times. If the pump(s) will not prime, shut off the power to the spa and call for service.

Important: A pump should not be allowed to run without priming for more than 2 minutes. Under NO circumstances should a pump be allowed to run without priming beyond the end of the 4-5 minute priming mode. Doing so may cause damage to the pump and cause the system to energize the heater and go into an overheat condition.

Exiting Priming Mode

You can manually exit Priming Mode by pressing the “Warm” or “Cool” button. Note that if you do not manually exit the priming mode as described above, the priming mode will be automatically terminated after 4-5 minutes. Be sure that the pump(s) have been primed by this time.

Once the system has exited Priming Mode, the top-side panel will momentarily display the set temperature but the display will not show the water temperature yet, as shown below.

This is because the system requires approximately 1 minute of water flowing through the heater to determine the water temperature and display it.



Spa Behavior

Pumps

Press the “Jets” button once to turn pump 1 on or off, and to shift between low and high speeds if equipped. If left running, the pump will turn off after a time-out period.

On non-circ systems, the low-speed of pump 1 runs when the blower or any other pump is on. If the spa is in Ready Mode (See page 6), Pump 1 low may also activate once in a while for at least 1 minute to detect the spa temperature (polling) and then to heat to the set temperature if needed. When the low-speed turns on automatically, it cannot be deactivated from the panel, however the high speed may be started.

Circulation Pump Modes

If the system is equipped with a circ pump, it will be configured to work in one of three different ways:

- 1, The circ pump operates continuously (24 hours) with the exception of turning off for 30 minutes at a time when the water temperature reaches 3°F (1.5°C) above the set temperature (most likely to happen in very hot climates).
- 2, The circ pump stays on continuously, regardless of water temperature.
- 3, A programmable circ pump will come on when the system is checking temperature (polling), during filter cycles, during freeze conditions, or when another pump or blower is on.

The specific Circulation Mode that is used has been determined by the Manufacturer and cannot be changed in the field.

Filtration and Ozone

On non-circ systems, Pump 1 low and the ozone generator will run during filtration. On circ systems, the ozone will run with the circ pump.

Most spas have one filter cycle per day, but some spas have two filter cycles per day. The first filter cycle occurs 6 minutes after power-up and then every 24 hours. The second filter cycle, if there is one, occurs 12 hours after the first one. The filter duration is programmable. (See page 7.)

At the start of each filter cycle, all water devices (other than the primary pump) will run briefly to purge the plumbing to maintain good water quality. The term “water devices” includes the Blower.

Freeze Protection

If the temperature sensors within the heater detect a low enough temperature, then the pump(s) and the blower automatically activate to provide freeze protection. The pump(s) and blower will run either continuously or periodically depending on conditions.

In colder climates, an optional freeze sensor may be added to protect against freeze conditions that may not be sensed by the standard sensors. Auxiliary freeze sensor protection acts similarly except with the temperature thresholds determined by the switch. See your dealer for details.

Clean-up Cycle (optional)

When a pump or blower is turned on by a button press, a clean-up cycle begins 30 minutes after the pump or blower is turned off or times out. The pump and the ozone generator will run for 30 minutes or more, depending on the system.

Temperature

Adjusting the Set Temperature

When using a panel with Up and Down buttons (Temperature buttons), pressing Up or Down will cause the temperature to flash. Pressing a temperature button again will adjust the set temperature in the direction indicated on the button. When the LCD stops flashing, the spa will heat to the new set temperature when required.

If the panel has a single temperature button, pressing the button will cause the temperature to flash. Pressing the button again will cause the temperature to change in one direction (e.g. UP). After allowing the display to stop flashing, pressing the Temperature Button will cause the temperature to flash and the next press will change the temperature in the opposite direction (e.g. DOWN).

Press-and-Hold

If a Temperature button is pressed and held when the temperature is flashing, the temperature will continue to change until the button is released. If only one temperature button is available and the limit of the Temperature Range is reached when the button is being held, the progression will reverse direction.

Mode – Ready and Rest

In order for the spa to heat, a pump needs to circulate water through the heater. The pump that performs this function is known as the “primary pump.”

The primary pump can be either a 2-Speed Pump 1 or a circulation pump.

If the primary pump is a 2-Speed Pump 1, Ready Mode (indicated by **R**) will circulate water periodically, using Pump 1 Low, in order to maintain a constant water temperature, heat as needed, and refresh the temperature display. This is known as “polling.”

Rest Mode (indicated by **☒**) will only allow heating during programmed filter cycles. Since polling does not occur, the temperature display may not show a current temperature until the primary pump has been running for a minute or two.

Circulation Mode (See Page 4, under Pumps, for other circulation modes)

If the spa is configured for 24HR circulation, the primary pump generally runs continuously. Since the primary pump is always running, the spa will maintain set temperature and heat as needed in Ready Mode, without polling.

In Rest Mode, the spa will only heat to set temperature during programmed filter times, even though the water is being filtered constantly when in Circulation Mode.

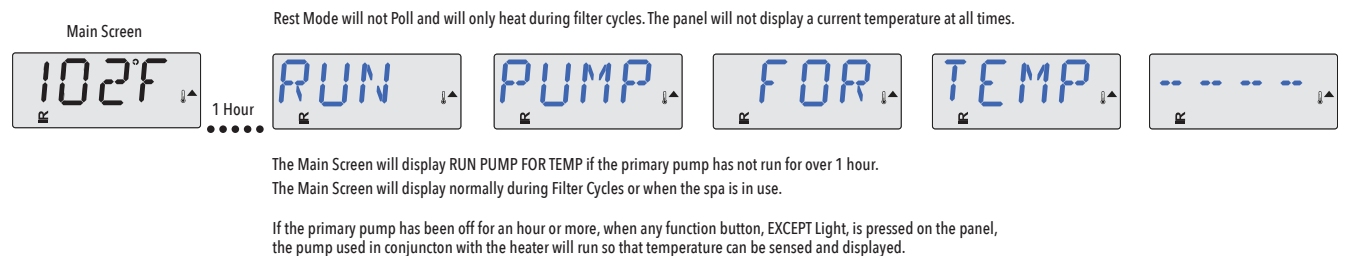
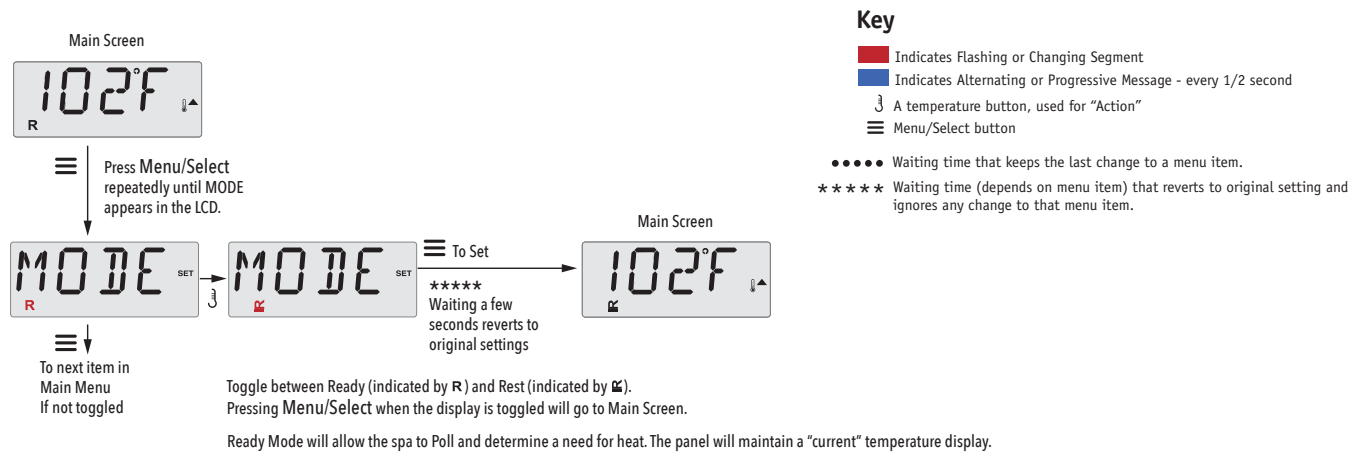

Ready-in-Rest Mode

R ☒ appears in the display if the spa is in Rest Mode and “Jets” is pressed. It is assumed that the spa is being used and will heat to set temperature. The primary pump will run until set temperature is reached, or 1 hour has passed. After 1 hour, the System will revert to Rest Mode. This mode can also be reset by entering the Mode Menu and changing the Mode.

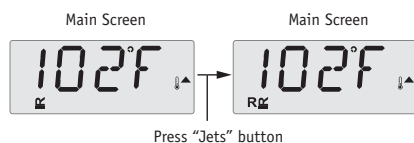

Flip (Invert Display)

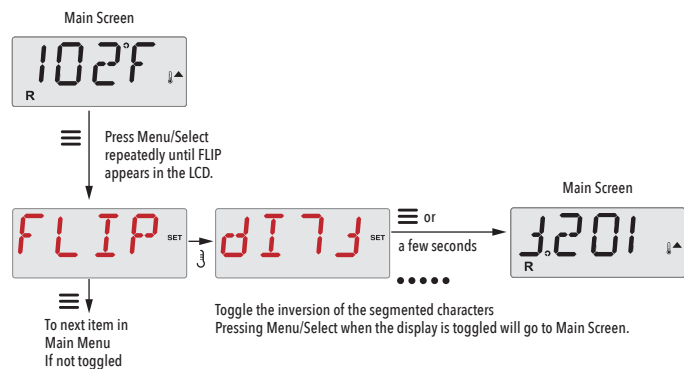

Key

- Indicates Flashing or Changing Segment
- Indicates Alternating or Progressive Message - every 1/2 second
- ⌵ A temperature button, used for "Action"
- ☰ Menu/Select button
- Waiting time that keeps the last change to a menu item.
- * * * * * Waiting time (depends on menu item) that reverts to original setting and ignores any change to that menu item.

Adjusting Filtration

Main Filtration

Filter cycles are set using a duration. The filter duration setting can be adjusted in 1-hour increments. Filter Cycle 1 and Filter Cycle 2 (if enabled) are set to the same duration.

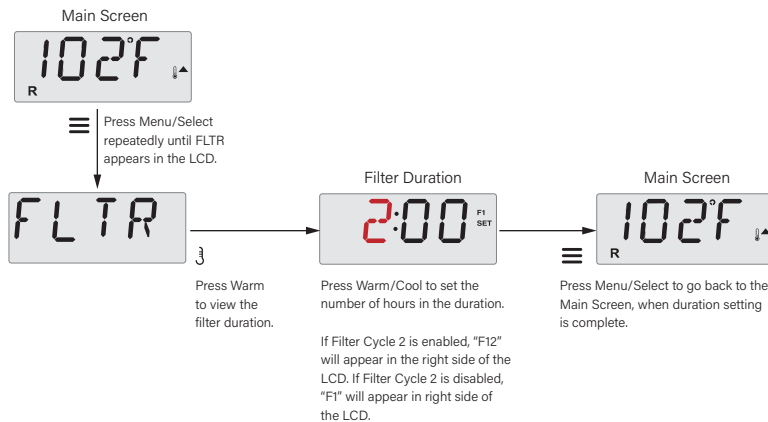

Purge Cycles

In order to maintain sanitary conditions, secondary Pumps and/or a Blower will purge water from their respective plumbing by running briefly at the beginning of each filter cycle.

General Messages



Priming Mode

Each time the spa is powered up, it will enter Priming Mode. The purpose of Priming Mode is to allow the user to run each pump and manually verify that the pumps are primed (air is purged) and water is flowing. This typically requires observing the output of each pump separately, and is generally not possible in normal operation. Priming Mode lasts 4 minutes, but you can exit it earlier by pressing any Temp button. The heater is not allowed to run during Priming Mode.

NOTE: If your spa has a Circ Pump, it will turn on with "Light" in Priming Mode. The Circ Pump will run by itself when Priming Mode is exited.



Water Temperature is Unknown

After the pump has been running for 1 minute, the temperature will be displayed.



Too Cold - Freeze Protection

A potential freeze condition has been detected, or the Aux Freeze Switch has closed, and all pumps and blower are activated, either one at a time, or all at once, depending on how your system was built. All pumps and blower are ON for at least 4 minutes after the potential freeze condition has ended, or when the aux freeze switch opens.

In some cases, pumps may turn on and off and the heater may operate during Freeze Protection.

This is an operational message, not an error indication.



Water is too Hot (OHS)

One of the water temp sensors has detected spa water temp 110°F (43.3°C) and spa functions are disabled. System will auto reset when the spa water temp is below 108°F (42.2°C). Check for extended pump operation or high ambient temp.



J29 Warning

J29 is typically used as a Heater Disable input. As such, it should not typically be shorted at power-up. This message appears if J29 is shorted at power-up.

* This message can be reset from the topside panel with any button press.

Heater-Related Messages

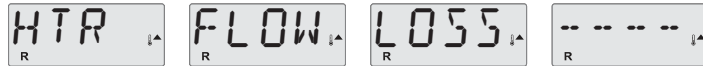

Heater Flow is Reduced (HFL)

There may not be enough water flow through the heater to carry the heat away from the heating element. Heater start up will begin again after about 1 min. See “Flow Related Checks” below.

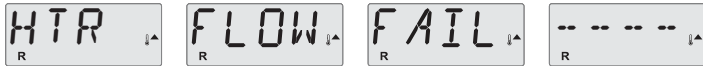

Heater Flow is Reduced (LF)*

There is not enough water flow through the heater to carry the heat away from the heating element and the heater has been disabled. See “Flow Related Checks” below. After the problem has been resolved, you must press any button to reset and begin heater start up.



Heater may be Dry (dr)*

Possible dry heater, or not enough water in the heater to start it. The spa is shut down for 15 min. Press any button to reset the heater start-up. See “Flow Related Checks” below.



Heater is Dry*

There is not enough water in the heater to start it. The spa is shut down. After the problem has been resolved, you must press any button to reset and restart heater start up. See “Flow Related Checks” below.



Heater is too Hot (OHH)*

One of the water temp sensors has detected 118°F (47.8°C) in the heater and the spa is shut down. You must press any button to reset when water is below 108°F (42.2°C). See “Flow Related Checks” below.



A Reset Message may Appear with other Messages.

Some errors may require power to be removed and restored.

Flow-Related Checks

Check for low water level, suction flow restrictions, closed valves, trapped air, too many closed jets and pump prime.

On some systems even when spa is shut down, some equipment may occasionally turn on to continue monitoring temperature or if freeze protection is needed.

* This message can be reset from the topside panel with any button press.

Sensor-Related Messages



Sensor Balance is Poor

The temperature sensors MAY be out of sync by or 3°F. Call for Service.



Sensor Balance is Poor*

The temperature sensors ARE out of sync. The Sensor Balance is Poor fault has been established for at least 1 hour. Call for Service.

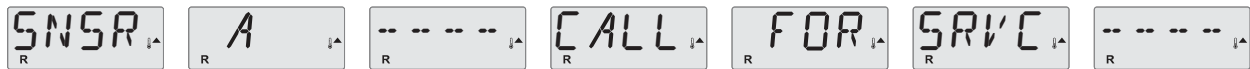

Sensor Failure – Sensor A, Sensor B

A temperature sensor or sensor circuit has failed. Call for Service.

Miscellaneous Messages



No Communications

The control panel is not receiving communication from the System. Call for Service.



Pre-Production Software

The Control System is operating with test software. Call for Service.



°F or °C is replaced by °T

The Control System is in Test Mode. Call for Service.

* This message can be reset from the topside panel with any button press.

System-Related Messages

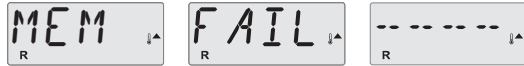

Memory Failure - Checksum Error*

At Power-Up, the system has failed the Program Checksum Test. This indicates a problem with the firmware (operation program) and requires a service call.



Memory Warning - Persistent Memory Reset*

Appears after any system setup change. Contact your dealer or service organization if this message appears on more than one power-up, or if it appears after the system has been running normally for a period of time.

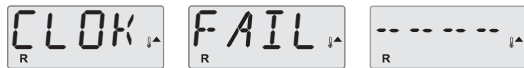

Memory Failure - Clock Error*

Contact your dealer or service organization.

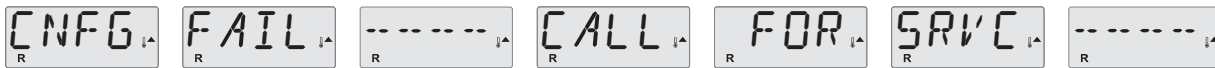

Configuration Error – Spa will not Start Up

Contact your dealer or service organization.

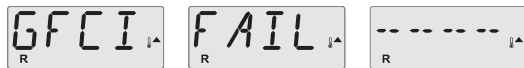

GFCI Failure - System Could Not Test/Trip the GFCI

NORTH AMERICA ONLY. May indicate an unsafe installation. Contact your dealer or service organization.

* This message can be reset from the topside panel with any button press.

System-Related Messages (Continued)



A Pump Appears to be Stuck ON

Water may be overheated. POWER DOWN THE SPA. DO NOT ENTER THE WATER. Contact your dealer or service organization.



A Pump Appears to have been Stuck ON when spa was last powered

POWER DOWN THE SPA. DO NOT ENTER THE WATER.
Contact your dealer or service organization.



The water level is too low

Some systems have a water level detect, and this message appears if it detects that the water level is too low.

Reminder Messages

General maintenance helps.

The display of Reminder Messages can be suppressed by using the PREF Menu. See Page 12.

Reminder Messages can be chosen individually by the Manufacturer. They may be disabled entirely, or there may be a limited number of reminders on a specific model.

The frequency of each reminder (e.g. 7 days) can be specified by the Manufacturer.

Press a Temperature button to reset a displayed reminder message.



Alternates with temperature or normal display.

Appears on a regular schedule, e.g. every 7 days.

Check pH with a test kit and adjust pH with the appropriate chemicals.



Alternates with temperature or normal display.

Appears on a regular schedule, e.g. every 7 days.

Check sanitizer level and other water chemistry with a test kit and adjust with the appropriate chemicals.

* This message can be reset from the topside panel with any button press.



Alternates with temperature or normal display.

Appears on a regular schedule, e.g. every 30 days.

Clean the filter media as instructed by the manufacturer. See HOLD on page 9.



Alternates with temperature or normal display.

Appears on a regular schedule, e.g. every 30 days.

The Ground Fault Circuit Interrupter (GFCI) or Residual Current Device (RCD) is an important safety device and must be tested on a regular basis to verify its reliability.

Every user should be trained to safely test the GFCI or RCD associated with the hot tub installation.

A GFCI or RCD will have a TEST and RESET button on it that allows a user to verify proper function.

Warning:

If freezing conditions exist, a GFCI or RCD should be reset immediately or spa damage could result. The end user should always trained to test and reset the GFCI or RCD on a regular basis.



Alternates with temperature or normal display.

Appears on a regular schedule, e.g. every 90 days.

Change the water in the spa on regular basis to maintain proper chemical balance and sanitary conditions.



Alternates with temperature or normal display.

Appears on a regular schedule, e.g. every 180 days.

Vinyl covers should be cleaned and conditioned for maximum life.



Alternates with temperature or normal display.

Appears on a regular schedule, e.g. every 180 days.

Wood skirting and furniture should be cleaned and conditioned per the manufacturers instructions for maximum life.



Alternates with temperature or normal display.

Appears on a regular schedule, e.g. every 365 days.

Filters should be replaced occasionally to maintain proper spa function and sanitary conditions.

Reminder Messages (Continued)



Alternates with temperature or normal display.

As needed.

Install new mineral cartridge.



Alternates with temperature or normal display.

Appears on a regular schedule, e.g. every 365 days.

Check your ozone and/or UV generator per your spa manufacturer's instructions.



Alternates with temperature or normal display.

Appears on a regular schedule, e.g. every 365 days.

Have a service technician do a check-up on your spa per your spa manufacturer's instructions.

Warning! Qualified Technician Required for Service and Installation

Basic Installation and Configuration Guidelines

Use minimum 6AWG copper conductors only.

Torque field connections between 21 and 23 in lbs.

Readily accessible disconnecting means to be provided at time of installation.

Permanently connected.

Connect only to a circuit protected by a Class A Ground Fault Circuit Interrupter (GFCI) or Residual Current Device (RCD) mounted at least 5' (1.52M) from the inside walls of the spa/hot tub and in line of sight from the equipment compartment.

CSA enclosure: Type 2

Refer to Wiring Diagram inside the cover of the control enclosure.

Refer to Installation and Safety Instructions provided by the spa manufacturer.

Warning: People with infectious diseases should not use a spa or hot tub.

Warning: To avoid injury, exercise care when entering or exiting the spa or hot tub.

Warning: Do not use a spa or hot tub immediately following strenuous exercise

Warning: Prolonged immersion in a spa or hot tub may be injurious to your health

Warning: Maintain water chemistry in accordance with the Manufacturers instructions.

Warning: The equipment and controls shall be located not less than 1.5 meters horizontally from the spa or hot tub.

Warning! GFCI or RCD Protection.

The Owner should test and reset the GFCI or RCD on a regular basis to verify its function.

Warning! Shock Hazard! No User Serviceable Parts.

Do not attempt service of this control system. Contact your dealer or service organization for assistance. Follow all owner's manual power connection instructions. Installation must be performed by a licensed electrician and all grounding connections must be properly installed.

CSA Compliance/Conformité

Caution:

- Test the ground fault circuit interrupter or residual current device before each use of the spa.
- Read the instruction manual.
- Adequate drainage must be provided if the equipment is to be installed in a pit.
- For use only within an enclosure rated CSA Enclosure 3.
- Connect only to a circuit protected by a Class A ground fault circuit interrupter or residual current device.
- To ensure continued protection against shock hazard, use only identical replacement parts when servicing.
- Install a suitably rated suction guard to match the maximum flow rate marked.

Warning:

- Water temperature in excess of 38°C may be injurious to your health.
- Disconnect the electrical power before servicing.

Attention:

- Toujours verifier l'efficacite du disjoncteur differentiel avant d'utiliser differentiel avant d'utiliser le bain.
- Lire la notice technique.
- Lorsque l'appareillage est installe dans une fosse, on doit assurer un drainage adequat.
- Employer uniquement a l'interieur d'une cloture CSA Enclosure 3.
- Connecter uniquement a un circuit protege par un disjoncteur differentiel de Class A.
- Afin d'assurer une protection permanente contre le danger de shock electrique, lors de l'entretien employer seulement des pieces de rechange identiques.
- Les prises d'aspiration doivent etre equipees de grilles convenant au debit maximal indique.

Avertissement:

- Des temperatures de l'eau superieures a 38°C peuvent presenter un danger pour la sante.
- Deconnecter du circuit d'alimentation electrique avante l'entretien.

Warning/Advertissement:

- Disconnect the electric power before servicing. Keep access door closed.
- Deconnecter du circuit d'alimentation electrique avant l'entretien. Garder la porte fermer.